



Audi R10



MARCA - CODICE	FOTO	NOTE
AVANT – 20526 (NERO) AVANT – 20534 (BIANCO) AVANT – 20535 (VERDE)		Solo con telai "TIPO 3"
AVANT – 20501		Solo con telai "TIPO 2"
AVANT – 20504		Telaio "TIPO 2"
AVANT – 20504B (NERO) AVANT – 20536 (BIANCO) AVANT – 20537 (VERDE)		Telai "TIPO 3"

NOTE:

- Peso minimo carrozzeria 15,5 grammi.



Lotus Elise GT1



MARCA - CODICE	FOTO	NOTE
AVANT – 20526 (NERO) AVANT – 20534 (BIANCO) AVANT – 20535 (VERDE)		Solo con telai "TIPO 3"
AVANT – 20501		Solo con telai "TIPO 2"
AVANT – 20504		Telaio "TIPO 2"
AVANT – 20504B (NERO) AVANT – 20536 (BIANCO) AVANT – 20537 (VERDE)		Telai "TIPO 3"

NOTE:

- Peso minimo carrozzeria 15,5 grammi.



Pescarolo



MARCA - CODICE	FOTO	NOTE
AVANT – 20526 (NERO) AVANT – 20534 (BIANCO) AVANT – 20535 (VERDE)		Solo con telai "TIPO 3"
AVANT – 20501		Solo con telai "TIPO 2"
AVANT – 20507		Telaio "TIPO 2"
AVANT – 20507B (NERO) AVANT – 20538 (BIANCO) AVANT – 20539 (VERDE)		Telai "TIPO 3"

NOTE:

- Peso minimo carrozzeria 15,5 grammi.



Peugeot 908



MARCA - CODICE	FOTO	NOTE
AVANT – 20526 (NERO) AVANT – 20534 (BIANCO) AVANT – 20535 (VERDE)		Solo con telai "TIPO 3"
AVANT – 20501		Solo con telai "TIPO 2"
AVANT – 20504		Telaio "TIPO 2"
AVANT – 20504B (NERO) AVANT – 20536 (BIANCO) AVANT – 20537 (VERDE)		Telai "TIPO 3"

NOTE:

- Peso minimo carrozzeria 15,5 grammi.



Porsche Spyder



MARCA - CODICE	FOTO	NOTE
AVANT – 20526 (NERO) AVANT – 20534 (BIANCO) AVANT – 20535 (VERDE)		Solo con telai "TIPO 3"
AVANT – 20501		Solo con telai "TIPO 2"
AVANT – 20504		Telaio "TIPO 2"
AVANT – 20504B (NERO) AVANT – 20536 (BIANCO) AVANT – 20537 (VERDE)		Telai "TIPO 3"

NOTE:

- Peso minimo carrozzeria 15,5 grammi.

BLACK ARROW ASTON MARTIN DBR9



MARCA - CODICE	FOTO	NOTE
BAMM01A		È possibile interporre uno spessore fra motore e supporto motore in corrispondenza delle viti di fissaggio, allo solo scopo di non far interferire l'albero motore con la gola della corona.
BACH01A		

NOTE:

- Peso minimo carrozzeria 15,5 grammi.
- Delle parti in lexan fornite come ricambio, si può utilizzare solo l'abitacolo. Il musetto ed i vetri devono restare di plastica, come quelli originali.



AUDI R8



MARCA - CODICE	FOTO	NOTE
NSR – 1250 (GIALLO) NSR – 1251 (BLU) NSR – 1252 (NERO) NSR – 1253 (BIANCO) NSR – 1254 (ROSSO)		E' possibile tagliare uno spicchio dell'anello che tiene la parte posteriore del motore (vicino a dove si saldano i fili).
NSR – 1232 (NERO) NSR – 1233 (BIANCO) NSR – 1234 (ROSSO)		Può essere lasciata libera di basculare. Omologata anche la forcella viola.
NSR – 1374 (BLU) NSR – 1375 (NERO) NSR – 1376 (BIANCO) NSR – 13 (GIALLO)		

NOTE:

- Peso minimo carrozzeria 15,5 grammi.



AUDI R18



MARCA - CODICE	FOTO	NOTE
NSR – 1250 (GIALLO) NSR – 1251 (BLU) NSR – 1252 (NERO) NSR – 1253 (BIANCO) NSR – 1254 (ROSSO)		E' possibile tagliare uno spicchio dell'anello che tiene la parte posteriore del motore (vicino a dove si saldano i fili).
NSR – 1232 (NERO) NSR – 1233 (BIANCO) NSR – 1234 (ROSSO)		Può essere lasciata libera di basculare. Omologata anche la forcella viola.
NSR – 1411 (BLU) NSR – 1412 (NERO) NSR – 1413 (BIANCO) NSR – 1410 (GIALLO)		

NOTE:

- Peso minimo carrozzeria 15,5 grammi.



CORVETTE C6



MARCA - CODICE	FOTO	NOTE
NSR – 1250 (GIALLO) NSR – 1251 (BLU) NSR – 1252 (NERO) NSR – 1253 (BIANCO) NSR – 1254 (ROSSO)		E' possibile tagliare uno spicchio dell'anello che tiene la parte posteriore del motore (vicino a dove si saldano i fili).
NSR – 1232 (NERO) NSR – 1233 (BIANCO) NSR – 1234 (ROSSO)		Può essere lasciata libera di basculare. Omologata anche la forcella viola.
NSR – 1397 (BLU) NSR – 1398 (NERO) NSR – 1399 (BIANCO) NSR – 1396 (GIALLO)		

NOTE:

- Peso minimo carrozzeria 15,5 grammi.



MOSLER MT900R



MARCA - CODICE	FOTO	NOTE
NSR – 1250 (GIALLO) NSR – 1251 (BLU) NSR – 1252 (NERO) NSR – 1253 (BIANCO) NSR – 1254 (ROSSO)		E' possibile tagliare uno spicchio dell'anello che tiene la parte posteriore del motore (vicino a dove si saldano i fili).
NSR – 1240 (GIALLO) NSR – 1241 (BLU) NSR – 1242 (NERO) NSR – 1243 (BIANCO) NSR – 1244 (ROSSO)		E' possibile tagliare uno spicchio dell'anello che tiene la parte posteriore del motore (vicino a dove si saldano i fili).
NSR – 1420 (BLU) NSR – 1421 (NERO) NSR – 1422 (BIANCO) NSR – 1419 (GIALLO)		
NSR – 1365 (BLU) NSR – 1366 (NERO) NSR – 1367 (BIANCO) NSR – 1391 (GIALLO)		

NOTE:

- Peso minimo carrozzeria 15,5 grammi.
- In caso di utilizzo dei banchini 124* è possibile modificare la sede del motore per poter adoperare le viti di fissaggio.
- Omologate tutte le forcelle per i banchini EVO4.



PORSCHE 997



MARCA - CODICE	FOTO	NOTE
NSR – 1250 (GIALLO) NSR – 1251 (BLU) NSR – 1252 (NERO) NSR – 1253 (BIANCO) NSR – 1254 (ROSSO)		E' possibile tagliare uno spicchio dell'anello che tiene la parte posteriore del motore (vicino a dove si saldano i fili).
NSR – 1232 (NERO) NSR – 1233 (BIANCO) NSR – 1234 (ROSSO)		Può essere lasciata libera di basculare. Omologata anche la forcella viola.
NSR – 1393 (BLU) NSR – 1394 (NERO) NSR – 1395 (BIANCO) NSR – 1392 (GIALLO)		

NOTE:

- Peso minimo carrozzeria 15,5 grammi.



MARCA - CODICE	FOTO	NOTE
SLOT.IT – CH49		La "barra di torsione" è facoltativa
<ul style="list-style-type: none"> SCALEAUTO – RT 3 (NERO) 		L'assale anteriore deve essere fissato nella posizione originale. Non può essere cambiato il foro di fissaggio.

NOTE:

- Peso minimo carrozzeria 15,5 grammi.



MARCA - CODICE	FOTO	NOTE
SLOT.IT – CH49		La "barra di torsione" è facoltativa
<ul style="list-style-type: none"> SCALEAUTO – RT 3 (NERO) 		L'assale anteriore deve essere fissato nella posizione originale. Non può essere cambiato il foro di fissaggio.

NOTE:

- Peso minimo carrozzeria 15,5 grammi.



Mercedes SLS GT3



MARCA - CODICE	FOTO	NOTE
SLOT.IT – CH49		La "barra di torsione" è facoltativa
<ul style="list-style-type: none">• SCALEAUTO – SC6613A (NERO)• SCALEAUTO – SC6613B (GRIGIO)• SCALEAUTO – SC6613C (GRIGIO CHIARO)		



NOTE:

- Il banchino SC-6520 non può essere utilizzato, anche se in dotazione con modelli nuovi.

Scaleauto
Model Car Competition Parts

Pagani Zonda



MARCA - CODICE	FOTO	NOTE
SLOT.IT – CH49		La "barra di torsione" è facoltativa
<ul style="list-style-type: none">• SCALEAUTO – SC6621A (NERO)• SCALEAUTO – SC6621B (GRIGIO)• SCALEAUTO – SC6621C (GRIGIO CHIARO)		

NOTE:

- Il banchino SC-6520 non può essere utilizzato, anche se in dotazione con modelli nuovi.

Scaleauto
Model Car Competition Parts

Radical SR-9



MARCA - CODICE	FOTO	NOTE
SLOT.IT – CH48		La "barra di torsione" è facoltativa
SCALEAUTO – SC6507		Le clip di tenuta delle bronzine è facoltativa
<ul style="list-style-type: none"> SCALEAUTO – SC6612 (NERO) SCALEAUTO – SC6612B (GRIGIO) SCALEAUTO – SC6612C (GRIGIO CHIARO) 		Telaio versione EVO1 (versione per banchini a 4 punti)
<ul style="list-style-type: none"> SCALEAUTO – SC6612A2 (NERO) SCALEAUTO – SC6612B2 (GRIGIO) SCALEAUTO – SC6612C2 (GRIGIO CHIARO) 		Telaio versione EVO2 (versione per banchini a 6 punti)

NOTE:

- Peso minimo carrozzeria 18 grammi.
- È possibile limare l'abitacolo originale per evitare l'interferenza dell'albero motore con la parte posteriore dell'abitacolo.
- Omologate entrambe le versioni delle carrozzerie (EVO1 e EVO2).
- Il banchino SC-6520 non può essere utilizzato, anche se in dotazione con modelli nuovi.
- **Nelle carrozzerie della prima serie è possibile abbassare la presa d'aria laterale della carrozzeria al massimo di 3mm. in corrispondenza del foro del telaio per i supporti laterali EVO6. Questo rende compatibili le vecchie carrozzerie con i nuovi telai.**



AUDI R18



MARCA - CODICE BANCHINO	FOTO	NOTE
SLOT.IT - CH49		La "barra di torsione" è facoltativa
SLOT.IT - CS24T-60 SLOT.IT - CS24T-60B		



NOTE:

- Peso minimo carrozzeria 15,5 grammi.
- E' possibile utilizzare solo il pick-up CH73 e **CH83 e CH88.**



AUDI R8 C RELOADED



MARCA - CODICE BANCHINO	FOTO	NOTE
SLOT.IT – CH48		La "barra di torsione" è facoltativa
SLOT.IT – CS12T-60		



NOTE:

- Peso minimo carrozzeria 18 grammi.
- Nel caso di utilizzo dell'abitacolo in lexan, sullo stesso le parti riprodotte le prese d'aria laterali vanno rimosse, per mantenere quelle originali



LOLA B09/60



MARCA - CODICE	FOTO	NOTE
SLOT.IT - CH48		La "barra di torsione" è facoltativa
SLOT.IT - CS22T-60 SLOT.IT - CS22T-60B		

NOTE:

- Peso minimo carrozzeria 15,5 grammi.
- E' possibile utilizzare solo il pick-up CH73 e **CH83 e CH88.**



MCLAREN F1 GTR



MARCA - CODICE BANCHINO	FOTO	NOTE
SLOT.IT - CH49		La "barra di torsione" è facoltativa
SLOT.IT - CS10T-60 SLOT.IT - CS10T-60B		

NOTE:

- Peso minimo carrozzeria: 15,5 grammi



NISSAN R390



MARCA - CODICE BANCHINO	FOTO	NOTE
SLOT.IT – CH49		La "barra di torsione" è facoltativa
SLOT.IT – CS04TAW		
SLOT.IT – CS14T-60		

NOTE:

- Peso minimo carrozzeria: 15,5 grammi.
- Dell'abitacolo originale fanno parte anche le turbine, quindi nel caso in cui lo si voglia sostituire con quello in lexan, le turbine vengono eliminate.



PORSCHE 911 EVO98



MARCA - CODICE	FOTO	NOTE
SLOT.IT - CH48		La "barra di torsione" è facoltativa
SLOT.IT - CS23T-60		

NOTE:

- Peso minimo carrozzeria 18 grammi.
- È possibile limare l'abitacolo originale per evitare l'interferenza dell'albero motore con la parte posteriore dell'abitacolo.

BRONZINE E CUSCINETTI OMOLOGATE

MARCA - CODICE	FOTO	NOTE
SLOT.IT - PA02		
SLOT.IT - PA32		
MB - 19022		
MB - 19025		
MB - 19050		

MB - 09051



MB - 09030



NSR - 4803
NSR - 4846
NSR - 4847



PRS - 32506

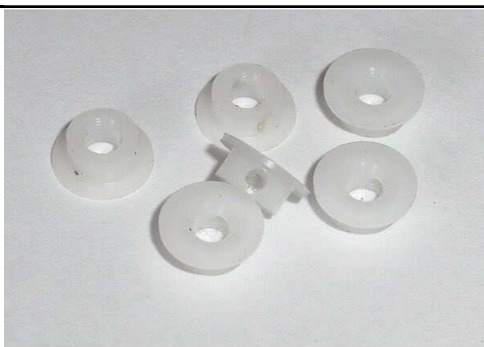

Solo su banchino scaleauto
SC6507

PRS - 32507

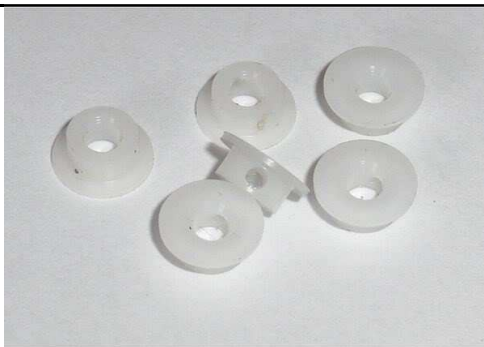

PRS – 32527



SLOTING PLUS – 1001



SLOTING PLUS – 1002



SLOTING PLUS - 1004



SLOTING PLUS – 1007



PICK UP OMOLOGATI

MARCA - CODICE	FOTO	NOTE
SLOT.IT – CH26		Utilizzabile anche la versione grigia
SLOT.IT – CH66		È possibile utilizzare un grano M2 per allargare la clip di fissaggio
SLOT.IT – CH73		Utilizzabile solo sulla Lola e Audi R18 Slot.it
SLOT.IT – CH 85		
SLOT.IT – CH 83		Utilizzabile solo sulla Lola e Audi R18 Slot.it
SLOT.IT – CH 88		Utilizzabile solo sulla Lola e Audi R18 Slot.it

MB – 17030

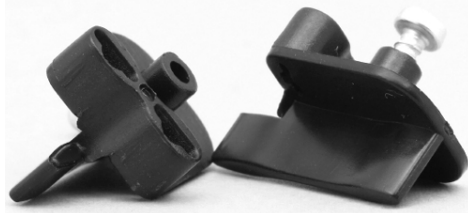

MB – 17031

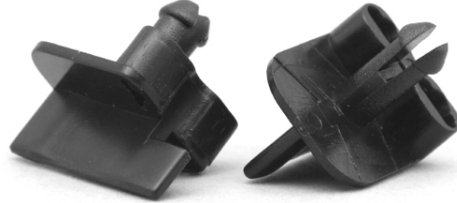

NSR – 4841



NSR – 4843



NSR – 4844



SCALEAUTO – 1605



SCALEAUTO – 1607



AVANT – 20508



SOSPENSIONI OMOLOGATE

MARCA - CODICE	FOTO	NOTE
SLOT.IT – CH09		Omologate anche i magneti in ferrite CN05 (neri)
SLOT.IT – CH47/B		Omologate le molle di ricambio CH55a – CH55b
MB - 19111		Omologate le molle 07007 Omologati i magneti 07008
MB – 07011		Omologate le molle 07007 Omologati i magneti 07008
MB – 09040		Omologate le molle 07007 Omologati i magneti 07008

NSR – 1209 (SOFT)
NSR – 1210 (MEDIUM)
NSR – 1211 (HARD)



NSR – 1228 (SOFT)
NSR – 1229 (MEDIUM)
NSR – 1230 (HARD)



AVANT – 20527



SLOTING – 801-1



Omologati anche i magneti
801-5

BASP01A
BASP02A
BASP03A
BASP04A

